

# POS<sub>T</sub> - Product Lift and Management Systems for Chest Freezers

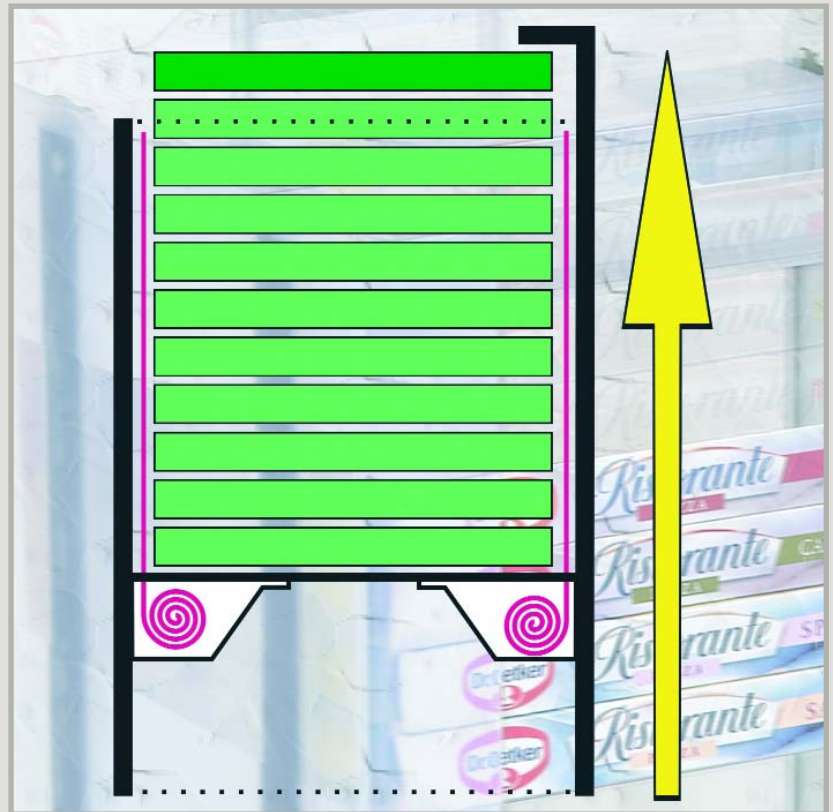

## The POS $\tau$ -Product Lift



A vertical spring loaded technical device, designed to continually push products in deep freezers or other presentational containers to a pre-defined height. E.G. up to the cooling limit when a product has been removed. At the same time a replica decal of the product in systematic order, is readily achieved within the freezer.

The POS  $\tau$  Pusher and Lifting Module has been recognized and received as a comprehensive system by our international customers, successfully achieving the desired presentation at the point of sale.

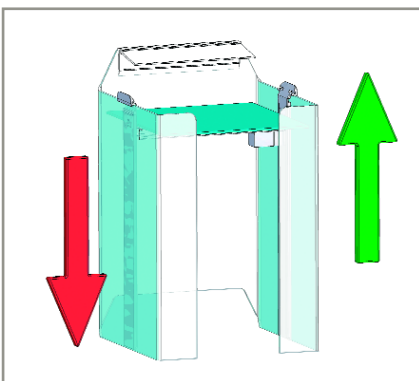

## Quality Features of the POS $\tau$ - Lifting System

### High efficiency factor - smooth lift

Stainless steel mainspring allowing the product to be lifted from the base into direct view ensuring accessibility at all times. The presentation is consistently delivered in a smooth but powerful manner.

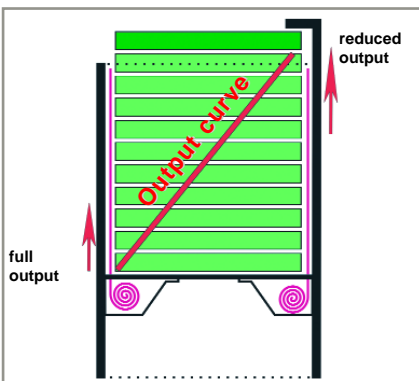

### Progressive Load Strength

proportionate to the charging level of the product stack in the lifting chamber.

This means: full lifting power for full product stacks, reduced lifting power for declining stock amounts.

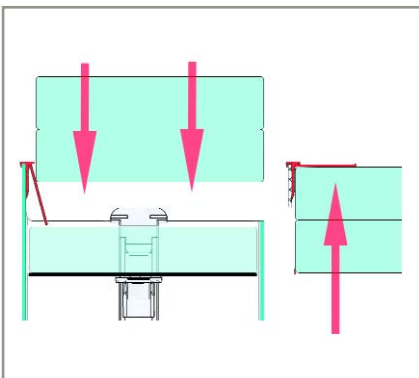

### User-Friendly

The delivered presentation will always ensure that the product is best placed for the consumer at all times.

A pendulous stopper prevents the products from lifted into adjacent compartments.



### Durable and Reliable

Our products carry the "GS" sticker for tested safety in accordance with the certification by the Technical Inspection Association.

## The Lifting and Shelf Management System for Chest Freezers

### ▶ Type Series A

consists of transparent **single chambers**, which are designed to accommodate the dimensions and specific weights of many commercially available products. Three lifting heights (28, 36 and 54 cm) are also available to optimize cooling space usage for different freezing unit models. All freezers can be individually filled using the single chamber system. We offer all sizes on the basis of product weight and dimension specifications.



Lifting chamber  
height 28 cm



Lifting chamber  
height 36 cm



Lifting chamber  
height 54 cm



## Examples of efficient "Lifting Solutions"

**Fish fingers in carton packages**  
(single lift)



**Fillet of fish vacuum packed in foil**  
(single lift)



**Fillet of fish vacuum packed in foil**  
(freezer installation)



**Herbs in small folded boxes**

without POS  $\gamma$ -Lifting System



with POS  $\gamma$ -Lifting System



### Type Series B (individually adapted to freezer type and stock layout) ◀

Consists of transparent **chamber rows** of a pre-defined width. By using adjustable compartment dividers and lifting lines within the individual sections different product depths can be set.

Our range is dependent on your current freezer planogram, taking into consideration the internal dimensions of the freezer as well as the product weight and size.

## The Benefits of the POS $\tau$ -Product Lift and Management Systems ...

... positioned in a continuous optimization of product presentations (also in existing facilities) with the following results:

- Increase of impulse buying through sales enhancing "full face presentation"  
2/3 of all purchase decisions are made at the Point of Sale
- Promotes healthy stock rotation (First in/First out)
- "Product pressure" for reduced stock as well
- Enhancement of the retail outlet
- Improved product presentation, convenient access at all times for the consumer, eliminating the need to hang over the freezer

**... for more success at the Point of Sale**



Maintaining accustomed on-shelf spots leads to easy product recognition.



A level indicator points out the need to refill to avoid out of stock situations.



The pendular stopper prevents products from being lifted into the unchilled range.



The pendular stopper is also an ideal spot for placing price labels directly at the product.

## Which lifting capacity (in "Newton") for which product?

The lifting capacity required depends on the following factors:

Product **height** and product **weight** (independent of lifting height 28, 36 or 54 cm).

The following table indicates at the interception point of height and weight the reference value for the recommended ideal lifting capacity. An "ideal capacity" will result in a smooth lift of the remaining stock up to the underside of the pendular stopper following each product removal.

Deviations from the "ideal capacity" are for the most part unproblematic and result in the following:

**Too little capacity** (at a higher specific product weight) will cause the lifting movement not to set in until the upper packages have been removed. The remaining stock will be lifted with a delay and may remain at certain distance under the pendular stopper.

**Too high capacity** (at a lower specific product weight) will result in a forceful lift up to the underside of the pendular stopper following each product removal. It ensures that the product remains in the given "cooling zone".

Weight up to	Product height in cm							
	from 1 cm	from 2 cm	from 3 cm	from 4 cm	from 5 cm	from 6 cm	from 8 cm	from 10 cm
1000 g					100 Newton	80 Newton	60 Newton	50 Newton
900 g				120 Newton	80 Newton	80 Newton	60 Newton	50 Newton
800 g				100 Newton	80 Newton	72 Newton	50 Newton	40 Newton
700 g			120 Newton	80 Newton	72 Newton	60 Newton	40 Newton	32 Newton
600 g			100 Newton	72 Newton	60 Newton	50 Newton	40 Newton	32 Newton
500 g		120 Newton	80 Newton	60 Newton	50 Newton	40 Newton	32 Newton	26 Newton
400 g		100 Newton	72 Newton	50 Newton	40 Newton	32 Newton	26 Newton	20 Newton
300 g		80 Newton	50 Newton	40 Newton	32 Newton	32 Newton	20 Newton	20 Newton
250 g	120 Newton	60 Newton	40 Newton	32 Newton	26 Newton	20 Newton	20 Newton	16 Newton
200 g	100 Newton	50 Newton	36 Newton	26 Newton	20 Newton	20 Newton	20 Newton	16 Newton
150 g	72 Newton	36 Newton	32 Newton	20 Newton	16 Newton	16 Newton	10 Newton	10 Newton
100 g	50 Newton	26 Newton	20 Newton	16 Newton	10 Newton	10 Newton	10 Newton	6 Newton
75 g	36 Newton	20 Newton	16 Newton	10 Newton	10 Newton	10 Newton	6 Newton	6 Newton
50 g	26 Newton	16 Newton	10 Newton	10 Newton	10 Newton	6 Newton	6 Newton	6 Newton
40 g	20 Newton	16 Newton	10 Newton	10 Newton	6 Newton	6 Newton	6 Newton	4 Newton
30 g	16 Newton	10 Newton	10 Newton	6 Newton	6 Newton	6 Newton	4 Newton	4 Newton