

POS_T - Representation of your Products on the shelf



POS τ - Representation of your Products on the shelf

Studies conclude: Investment in the quality of product presentation at the Point of Sale is proven to be strongly successful.

Implement the following advantages:

- Increase impulse buying through a permanent “front shelf edge presentation”
- Reduction in shelf maintenance by automatic product pusher or lift system
- Product-pressure achieved through Category Management and brand segmentation
- Elevate the presentation from a “Premium” presentation to an “Eye-catcher”

Our experienced team of Category Managers, Shop Fitting Experts and Design Engineers are happy to assist you from the initial concept and development through to delivering your “Successful Presentations”.

Our “Toolbox” of proven standard components engages as a solid and efficient platform combined with our proverbial creativity, offer the desired advantage for your products at the POS!



▶ Product Family presented with POS τ - Shelf Management System combined with product pusher

Flexible, suitable for many product assortments

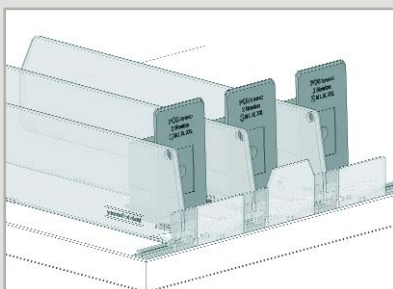

All information concerning this product range is available in our brochures and parts lists “POS τ -Pusher System” / “POS τ -Shelf Management System”

► **Product Family presented with POS τ - Compartment Pusher**

Product separation and the product pusher achieved in one single component - ideal for round or oval products.



All information concerning this product is available in our brochures and parts list "POS τ -Compartment Pusher"

► **Product Family presented with POS τ - System Tray**

The front stop is an ideal communication tool for the placement of brand or product logos. The spot reserved for your product is permanently secured and you can even save on the costly print of the trays.

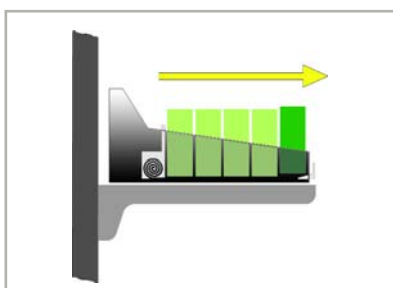
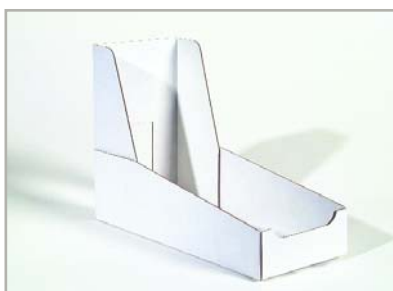

All information concerning this product is available in our brochures and parts list "POS τ -System Tray"

▶ **Product Family presented with POS 7 - shelf management system incorporating product pusher and “Brandline” – a visually unique presentation of your categories**

With optional integrated LED-lighting your presentation becomes an “eye catcher”!

Brandline 20 mm / 40 mm without LED



Brandline with variable LED-Lighting



All information concerning this product is available in parts list “POS 7 - Adapter-T and Scanner Profiles”

▶ **POS T - Light**
- the effective shelf lighting

Available now in new LED technique

Light creates purchase impulse
Brand promotion creates image
POS T - Light does both!

All information concerning this product is available in our brochures and parts list "POS T-Light"

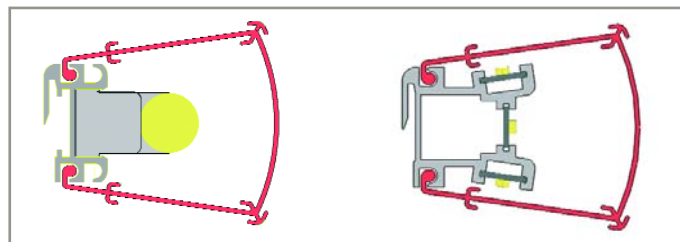

▶ **POS T - Front spot illumination**

Turning your product into a star!

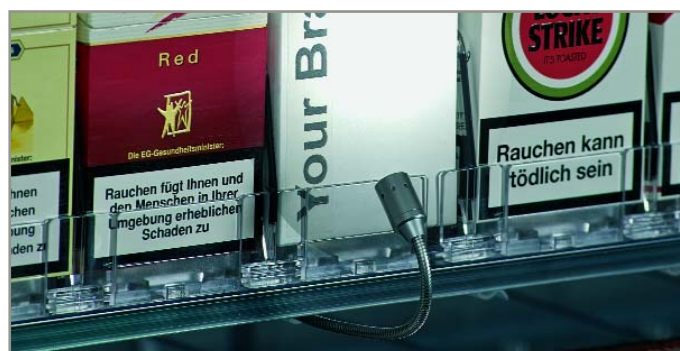

▶ **POS T - Magic Divider**

Equipped with our LED unit all dividers can turn into a luminous "Magic Divider".

All information concerning this product is available in our brochures and parts list "POS T - Shelf Management System"



▶ **POS T - Slide Light A2**

For your communication message on the shelf

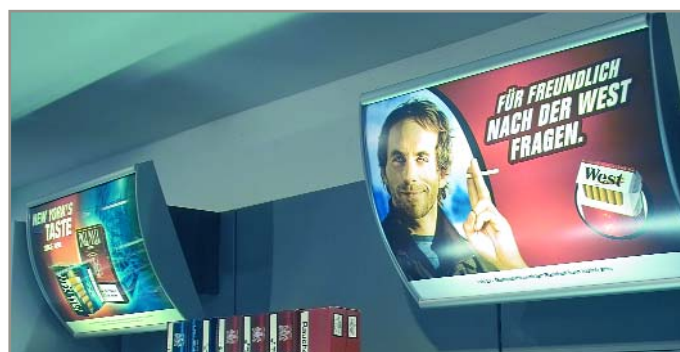

All information concerning this product is available in our brochures and parts list "POS T - Functional elements for the presentation of tobacco products"

POS τ - Bespoke Solutions

“The Product is the attraction” – and deserves an adequate experience at the Point of Sale, hence the presentation plays a significant role in the performance.

Where the POS τ - Shelf management system reaches its limit, our experienced category managers and engineering specialists develop and design a solution for a successful presentation of your product.

Expertise, creativity and latest technical equipment establish the platform for enhancing ...

Trays produced from plastic material, laser cut and formed

establishing a relationship to all categories and product families in conjunction the integrated product pusher offers:

- Top presentation
- Permanent reservation of usual front place
- Quick shelf replenishment

Related Products presented with POS τ - Brand Tray manufactured in bent acrylic

equipped with flexible dividers and inclined pushers 10 Newton for chocolate presentation



... your success at the Point of Sale



Acrylic Glide Server - Products slide by gravity to the front of the shelf.



Acrylic Tray with pushers and dividers - also stockable



Acrylic Tray with pushers and dividers - front with brand label



Customized tray for one facing including pusher - front with brand label

► POS T - Brand Trays from bent acrylic, with a stackable function and product pusher

Establish additional space on the 2nd tier

... the solution for low products



“Primus inter pares” (first choice amongst others)

- Present your product in focus of the consumer

... ideal e.g. for your Premium instant visual draw!

▶ Product family with LED- Frame

- LED-technique offers



▶ 3D - Passepartout

- With depth effect



▶ POS T - BIG Magic Divider with LED-Lighting

- For creating a 'stunning' effect



um Product or for market launch. With the use of color, light and print your product becomes an

► **Inclined Presentation**

- Different stands out



► **Double Stock**

- Creating more impact - building brand communication



► **Frame Presentation**

- Focal point for the consumer



► Product families presented with POS 7 - Displays

Provides the exclusive framing for your premium product range

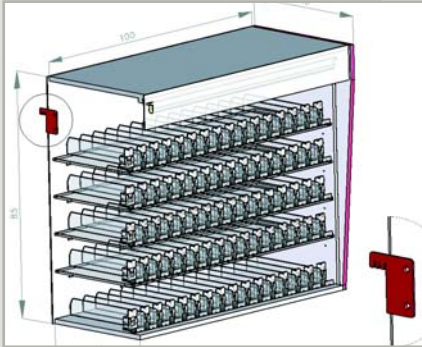

► **Brand Staging on the shelf**

With highlighters, shelf talkers, decoration, lighting, usual front place labeling, we can convert existing shelves into an exclusive **Brand Center**.

Plug-in, clamping, Velcro or magnetic connectors enable semi – permanent promotion and do not leave any visible signs upon removal.

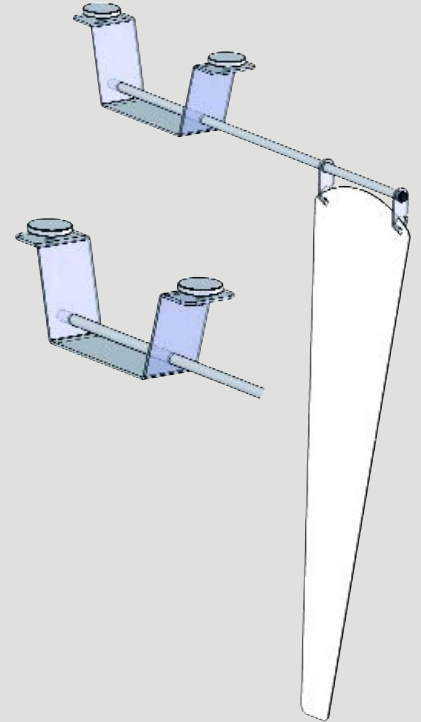

Vertical presentation with product lift offers many advantages:



- Large range of products on small surface
- Products are lifted from inconvenient depth to consumer sight and access and promote impulse buying
- Permanent First in First out inventory achieved through channels

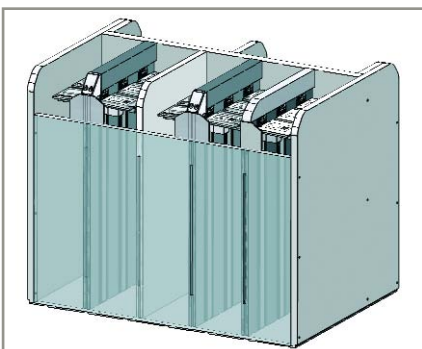
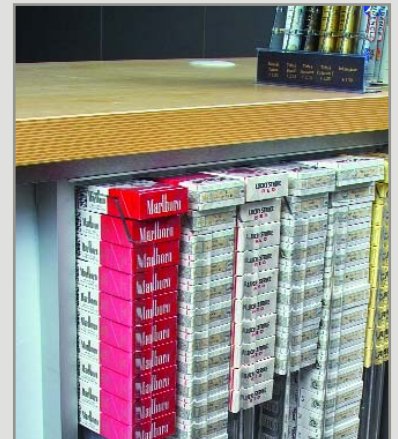
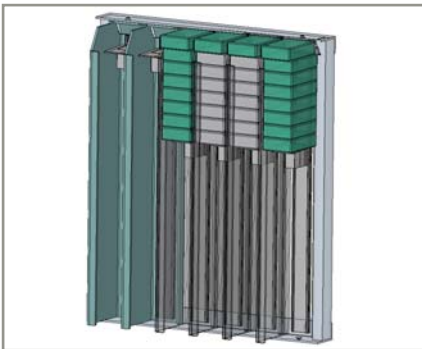
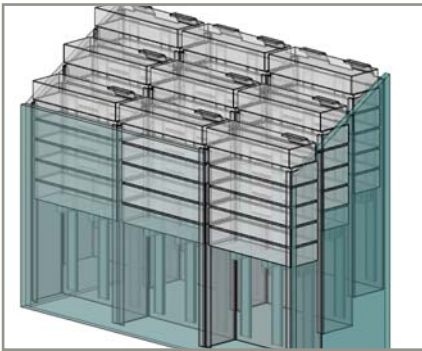

... as a "Lift" in chest freezers

The POS T - Product Lift Management System for chest freezers increases impulse buying and buying convenience.

Cutting edge technology achieves presentation for all frozen products, in various lifting heights and capacities.

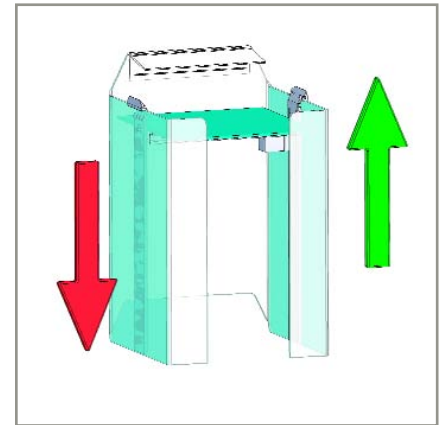

All information concerning this product is available in our brochures and parts list "POS T - Product Lift and Management System for Chest Freezers"

POS T - Profilierung Ihrer Produkte im Regal

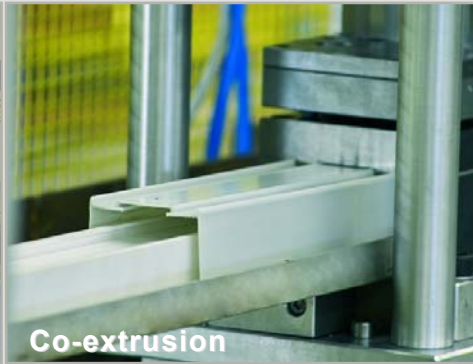

Competent knowledge in the following areas provides a solid platform for our creative developments:

POS Marketing

Shop Fitting and Display Manufacture

Category-Management and ECR (Efficient Consumer Response)

Technical implementation and know-how is achieved through our qualified consultants, assisted by the latest in technological machinery, ergonomically achieving and delivering a rational operation.

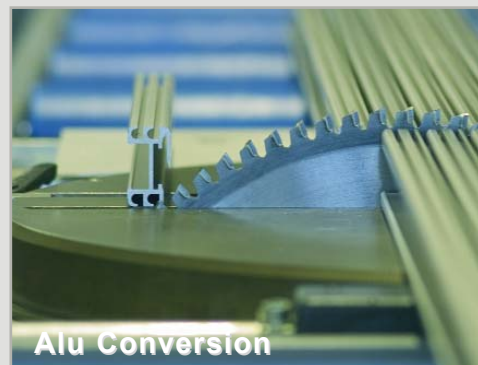

POSTUNING[®]
Udo Voßhenrich
... for more success at the Point of Sale

POS TUNING Udo Voßhenrich GmbH & Co. KG

Am Zubringer 8 / Industriegebiet Meerbrede
32107 Bad Salzufen - Germany
Fon + 49 (0) 52 22 - 3 69 65-0
Fax + 49 (0) 52 22 - 3 69 65-20
info@postuning.com
www.postuning.com