

POS_T - Duo-Compartment- Pusher for Deep Freezers and Cooling Shelves



The POS T-Duo Compartment Pusher-System



a purpose designed system to maintain order within deep freezers and additionally increase impulse buying through a permanent “front shelf edge presentation”. Any deep freezer can efficiently and economically be converted by application of a few components matched to the filling depth.

The flexible and movable system easily adapts to your current shelf planogram or implementation of future changes to the planograms. With 2 “base widths” all product dimensions continuously can be presented with optimal use of space.

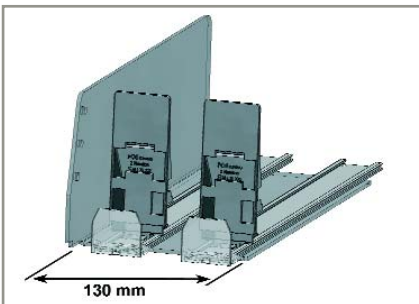

POS T-Duo Compartment Pusher

Duo-Compartment Pusher with integrated Divider H120 mm from transparent, frost-proof plastic material accommodates large-sized and heavy **products with widths from 120 to 190 mm**, with 2 pusher lines of 10 Newton each, for cabinet depths from 405 to 580 mm

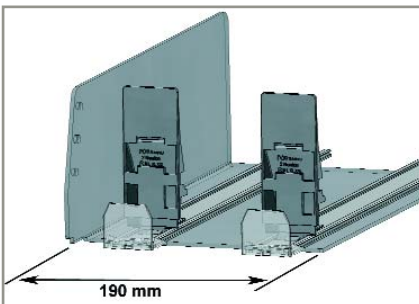

Duo-Compartment Pusher with integrated Divider H120 mm from transparent, frost-proof plastic material accommodates large-sized and heavy **products with widths from 180 to 300 mm**, with 2 pusher lines of 14 Newton each, for cabinet depths from 405 to 580 mm

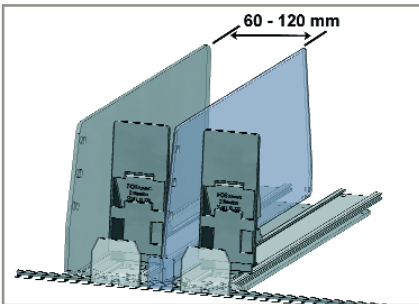

Divider H120; For the separation and segmentation of **products in widths of 60 – 120 mm** or as compartment end divider

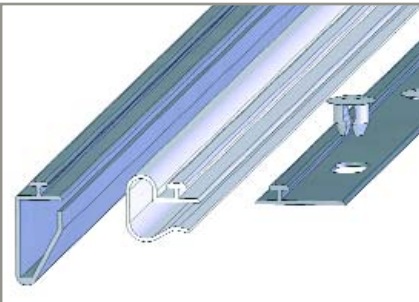

All type of shelves in deep freezers can be equipped with an adapter t-rail for an adjustable installation of individual Duo-Compartment Pushers



Durable and safe in operation

Our pushers carry the “GS” sticker for tested safety in accordance with the certification by the Technical Inspection Association (TÜV).

An increasing number of frozen products are being presented in high

Considering the high setup and energy cost an optimal sales success is of vital economic relevance!

The quality of product presentation in deep freezers therefore takes on an increasingly significant role. Fact is: Only products in optimal view result to impulse purchasing, due to the 1st impression being of paramount importance to trial!

Studies prove: 2/3 of all purchase decisions are made at the Point of Sale !

With the Duo-Compartment Pusher you present all products in a neat appearance within the lighted area at the forefront of the deep freezer. No costly shelf maintenance is required.

This generates impulse buying!



Without pusher front presentation the products on the upper shelf can neither be seen nor reached by smaller people.



With pusher front presentation the products on the upper shelf can be seen and reached also by smaller people.



Visibility and accessibility are **senior-oriented** and **“convenient”**

h-quality deep freezers

Two smaller products share one Compartment“. An additional divider (as accessory) provides product separation.



The transparent railing provides optimal presentation for „soft“ products.



The product selection already primed prior to the opening of the door and the opening duration is decreased and thus the energy use.



Visibly presented, easy to reach and continuous „product pressure“ even in case of reduced stock levels.



All information concerning this product is available in our price and type list „Duo-Compartment Pusher“.

Bespoke Solutions for Presentation of all Frozen Products ...



Example: Optimization of a Pizza presentation within existing installations

Initial Situation:

3 Pizzas next to each other, almost no room for dividers. Presentation mostly carried out in horizontal position.

An upright presentation was only possible in front area as the consoles inhibited a deeper stock level.

Doorposts avoid a comfortable withdrawal of the outer Pizzas.

Conclusion:

inadequate presentation
stock level is limited
withdrawal inconvenient

Presentation after POS 7 - Optimization:

Consoles in optimized shape allow **maximum stock level**.

Product pusher allows **upright presentation** and thus a pre-selection outside the deep freezer.

The centre facing is offset by 1 ½ product depth to rear. The products to the left and right that are partially covered by the doorposts can **easily be withdrawn** via the centre.

Conclusion:

maximized filling capacity
optimized presentation
more convenient withdrawal

... for more success at the point of Sale



For the food industry we manufacture branded Compartments, tailor made to the individual product dimensions and ...



... special solutions for Pizza



... product slide for ice cream containers

Turn your chest freezer into a segmented impulse buying system!

Extract from our brochure POS T-Lift and Management Systems for Chest Freezers”



Fish fingers in carton packages
(single lift)



Filet of fish shrink-wrapped
(single lift)



Filet of fish shrink-wrapped
(freezer installation)



The pendular stopper prevents products from being lifted into the unchilled range.



A level indicator points out the need to refill to avoid out of stock situations.

Kindly request our offer for an optimization of your frozen products presentation.