

# “Offeratio”

## Labelling and Shelf Management System for Pharmacies

### Labelling system - ideal for Pharmacies



The price label holder is compatible with all types of shelving, offering a non-reflective appearance. This system will compliment the appearance of your existing Pharmacy shop-fittings, whilst consistently delivering clear communication.

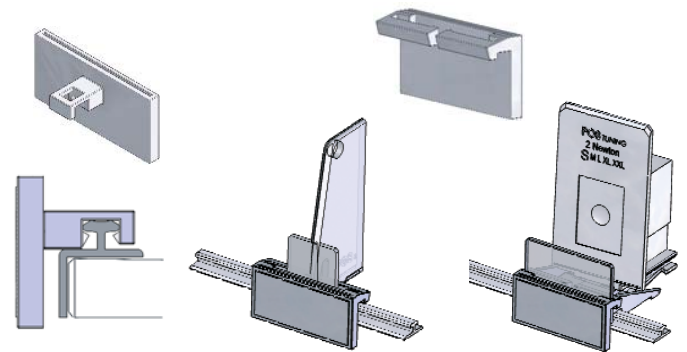

Price label holders 42 mm x 20 mm for mounting on compartment dividers, product pushers, adapter-T-rails or as free standing, uses label sizes of 38 mm x 17 mm.

### Personalized Labels

Design and produce individual labels direct from your PC. A perforated label sheet and relevant supporting software complete the package.

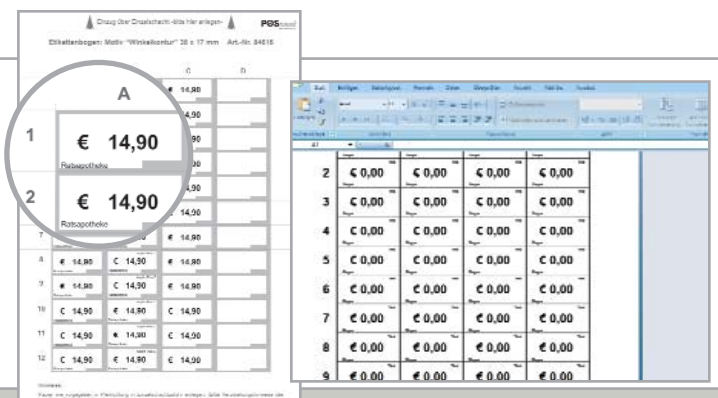

References + Solutions

## Flexible Information Holders



A stylish information point designed to assist your customers when faced with making a decision; I.E. Benefits, features and strengths of your product range.

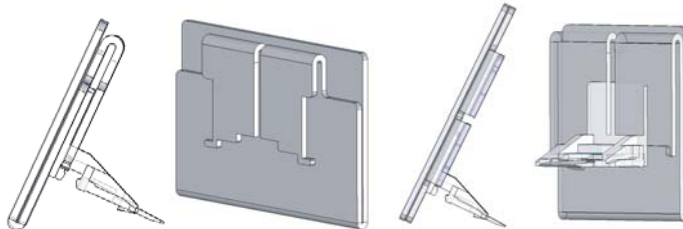

Info holders, made of acrylic (width 87 mm x height 57 mm and width 43 mm x height 57 mm), for mounting vertically or horizontally on compartment dividers or product pushers, take label sizes of 85 mm x 55 mm or 42 mm x 55 mm.

## Clear Compartment Dividers



A neat appearance is continuously achieved offering a good clear product overview. The system is compatible with all types of existing shelving.

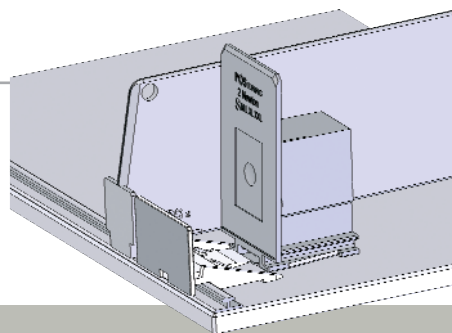

## Automatic Product Pusher



...for a consistently optimized product presentation without the efforts of shelf maintenance.

References + Solutions